

EE 508

Lecture 15

Filter Transformations

Lowpass to Bandpass

Review from Last Time

Theorem: If the perimeter variations and contact resistance are neglected, the standard deviation of the local random variations of a resistor of area A is given by the expression

$$\sigma_{\frac{R}{R_N}} = \frac{A_\rho}{\sqrt{A}}$$

Theorem: If the perimeter variations are neglected, the standard deviation of the local random variations of a capacitor of area A is given by the expression

$$\sigma_{\frac{C}{C_N}} = \frac{A_C}{\sqrt{A}}$$

Theorem: If the perimeter variations are neglected, the variance of the local random variations of the normalized threshold voltage of a rectangular MOS transistor of dimensions W and L is given by the expression

$$\sigma_{\frac{V_T}{V_{T_N}}}^2 = \frac{A_{V_{T0}}^2}{V_{T_N}^2 WL} \quad \text{or as} \quad \sigma_{\frac{V_T}{V_{T_N}}}^2 = \frac{A_{V_T}^2}{WL}$$

Review from Last Time

Theorem: If the perimeter variations are neglected, the variance of the local random variations of the normalized C_{OX} of a rectangular MOS transistor of dimensions W and L is given by the expression

$$\sigma_{\frac{C_{OX}}{C_{OXN}}}^2 = \frac{A_{COX}^2}{WL}$$

Theorem: If the perimeter variations are neglected, the variance of the local random variations of the normalized mobility of a rectangular MOS transistor of dimensions W and L is given by the expression

$$\sigma_{\frac{\mu_R}{\mu_N}}^2 = \frac{A_{\mu}^2}{WL}$$

where the parameters A_x are all constants characteristic of the process (i.e. model parameters)

- The effects of edge roughness on the variance of resistors, capacitors, and transistors can readily be included but for most layouts is dominated by the area dependent variations
- There is some correlation between the model parameters of MOS transistors but they are often ignored to simplify calculations

Review from Last Time

Statistical Modeling of dimensionless parameters - example

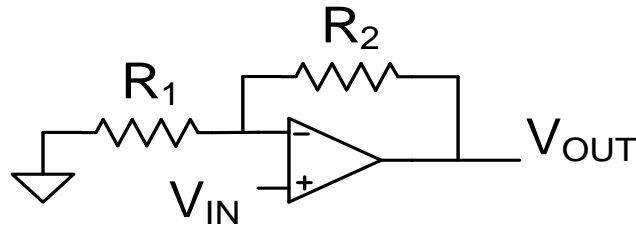

$$K = 1 + \frac{R_2}{R_1}$$

Assume common centroid layout
area of R_1 is $100\mu^2$ $A_p = .01\mu\text{m}$

Determine the yield if the nominal gain is $10 \pm 1\%$

$$\frac{K}{K_N} \cong N(1, 0.00095)$$

$$\frac{\frac{K}{K_N} - 1}{0.00095} \propto N(0, 1)$$

$$9.9 < K < 10.1$$

$$.99 < \frac{K}{K_N} < 1.01$$

$$-10 < \frac{\frac{K}{K_N} - 1}{.00095} < 10$$

$$-.01 < \frac{K}{K_N} - 1 < .01$$

The gain yield is essentially 100%

Could substantially decrease area or increase gain accuracy if desired

Review from Last Time

Statistical Modeling of dimensionless parameters - example

$$K = 1 + \frac{R_2}{R_1}$$

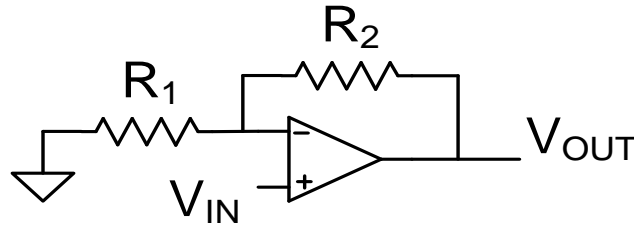

$$A_p = .025 \mu\text{m} \quad A_{R1} = 10 \mu\text{m}^2$$

$$\sigma_{\frac{R_{PROC}}{R_{NOM}}} = 0.2$$

Determine the yield if the nominal gain is $10 \pm 1\%$

$$\frac{K}{K_N} \propto N(1, 0.0075)$$

$$\frac{\frac{K}{K_N} - 1}{0.0075} \propto N(0, 1)$$

$$9.9 < K < 10.1$$

$$.99 < \frac{K}{K_N} < 1.01$$

$$-1.33 < \frac{\frac{K}{K_N} - 1}{.0075} < 1.33$$

$$-.01 < \frac{K}{K_N} - 1 < .01$$

$$Y = 2F_{N(0,1)}(1.33) - 1 = 2 \cdot .9082 - 1 = 0.8164$$

Dramatic drop from 100% yield to about 82% yield!

Review from Last Time

Statistical Modeling of Filter Characteristics

The variance of dimensioned filter parameters (e.g. ω_0 , poles, band edges, ...) is often very large due to the process-level random variables which dominate

The variance of dimensionless filter parameters (e.g. Q, gain, ...) are often quite small since in a good design they will depend dominantly on local random variations which are much smaller than process-level variations

The variance of dimensionless filter parameters is invariably proportional to the reciprocal of the square root of the relevant area and thus can be managed with appropriate area allocation

Linearization of Functions of a Random Variable

- Characteristics of most circuits of interest are themselves random variables
- Relationship between characteristics and the random variables often highly nonlinear
- Ad Hoc manipulations (repeated Taylor's series expansions) were used to linearize the characteristics in terms of the random variables

$$Y \cong Y_N + \sum_{i=1}^n (a_i x_{Ri})$$

- This is important because if the random variables are uncorrelated the variance of the characteristic can be readily obtained

$$\sigma_Y^2 \cong \sum_{i=1}^n (a_i^2 \sigma_{x_{Ri}}^2)$$

$$\frac{\sigma_Y^2}{Y_N^2} \cong \frac{1}{Y_N^2} \cdot \sum_{i=1}^n (a_i^2 \sigma_{x_{Ri}}^2)$$

- This approach was applicable since the random variables are small
- These Ad Hoc manipulations can be formalized and this follows

Review from Last Time

Formalization of Statistical Analysis

$$Y = f(x_{1N}, x_{2N}, \dots, x_{nN}, x_{1R}, x_{2R}, \dots, x_{nR}) = f([X_N], [X_R])$$

$$\sigma_{\frac{Y}{Y_N}}^2 = \frac{1}{Y_N^2} \sum_{i=1}^n \left(\left[\frac{\partial f}{\partial x_i} \right]_{[X_N], [X_R]=[0]} \right)^2 \cdot \sigma_{x_{Ri}}^2$$

Recall:

$$S_x^f = \frac{\partial f}{\partial x} \frac{x}{f} \quad \xrightarrow{Y=f} \quad \left(\frac{\partial f}{\partial x_i} \right)^2 \Big|_{[X_N], [x_R]=0} = \left(S_{x_i}^f \right)^2 \Big|_{[X_N], [x_R]=0} \cdot \frac{Y_N^2}{X_{Ni}^2}$$

Thus:

$$\sigma_{\frac{Y}{Y_N}}^2 = \sum_{i=1}^n \left(\left[S_{x_i}^f \right]_{[X_N]} \right)^2 \cdot \sigma_{\frac{x_{Ri}}{X_{Ni}}}^2$$

- Sensitivity analysis often used for statistical characterization of filter performance
- This is often much faster and less tedious than doing the linearization as described above though actually concepts are identical

Filter Design Process

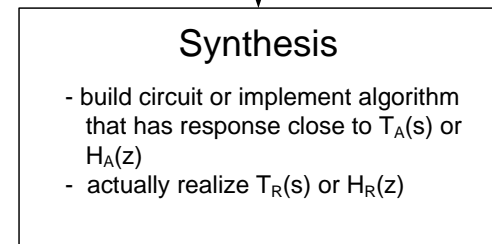
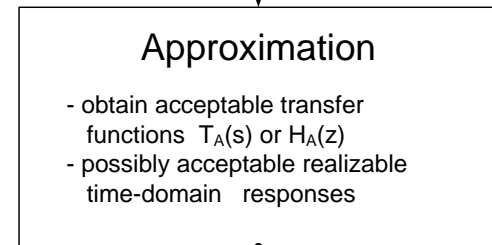
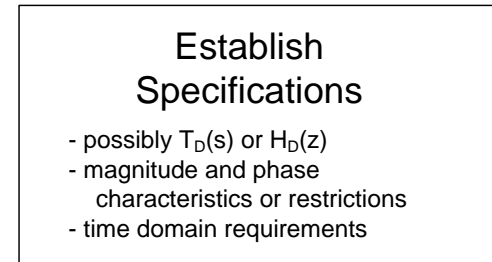

Filter

Have been focusing on the Approximation Problem
Classical approximations have been all lowpass
Will now obtain BP, HP, and BR approximations

Could repeat the process used for LP approximations but will use simple transformations to obtain Classical BP, HP and BR approximations

Filter Transformations

Lowpass to Bandpass	(LP to BP)
Lowpass to Highpass	(LP to HP)
Lowpass to Band-reject	(LP to BR)

Approach will be to take advantage of the results obtained for the standard LP approximations

Will focus on flat passband and zero-gain stop-band transformations

Will focus on transformations that map passband to passband and stopband to stopband

Filter Transformations

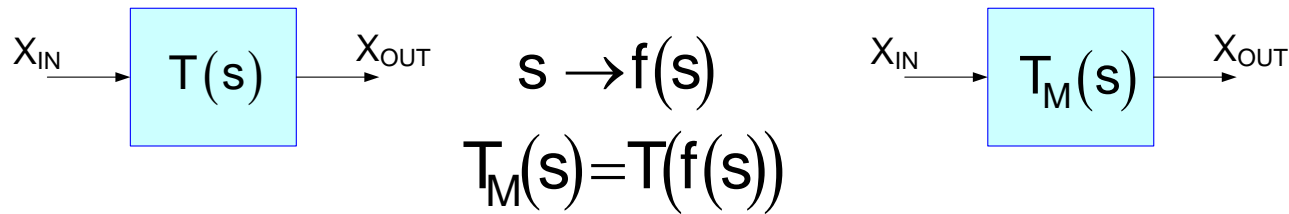

Claim:

If the imaginary axis in the s -plane is mapped to the imaginary axis in the s -plane with a variable mapping function, the basic shape of the function $T(s)$ will be preserved in the function $T(f(s))$ but the frequency axis may be warped and/or folded

Preserving basic shape, in this context, constitutes maintaining features in the magnitude response of $T(f(s))$ that are in $T(s)$ including, but not limited to, the peak amplitude, number of ripples, peaks of ripples,

Example: Shape Preservation

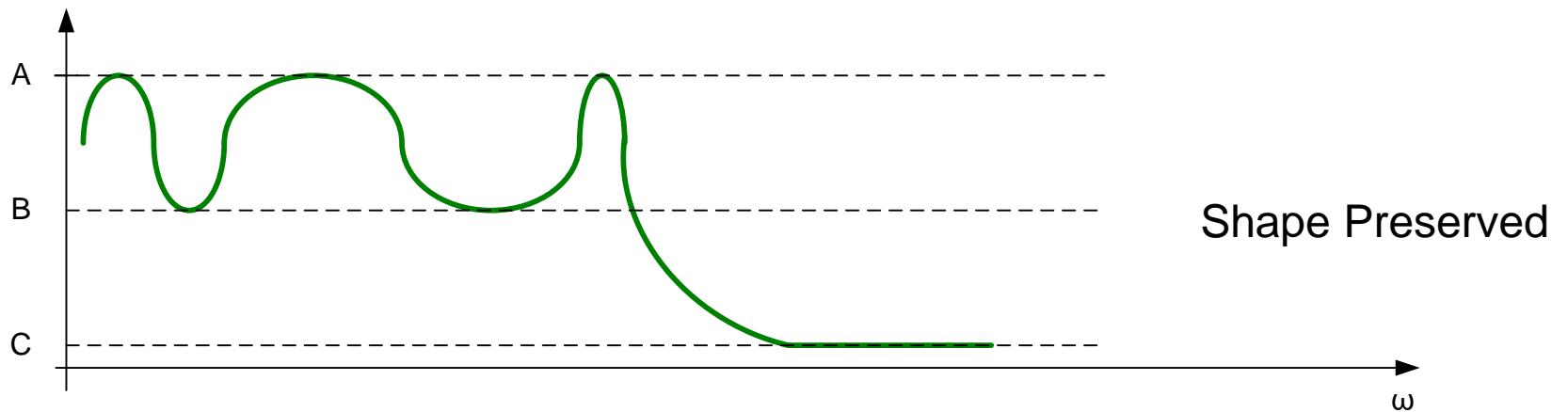
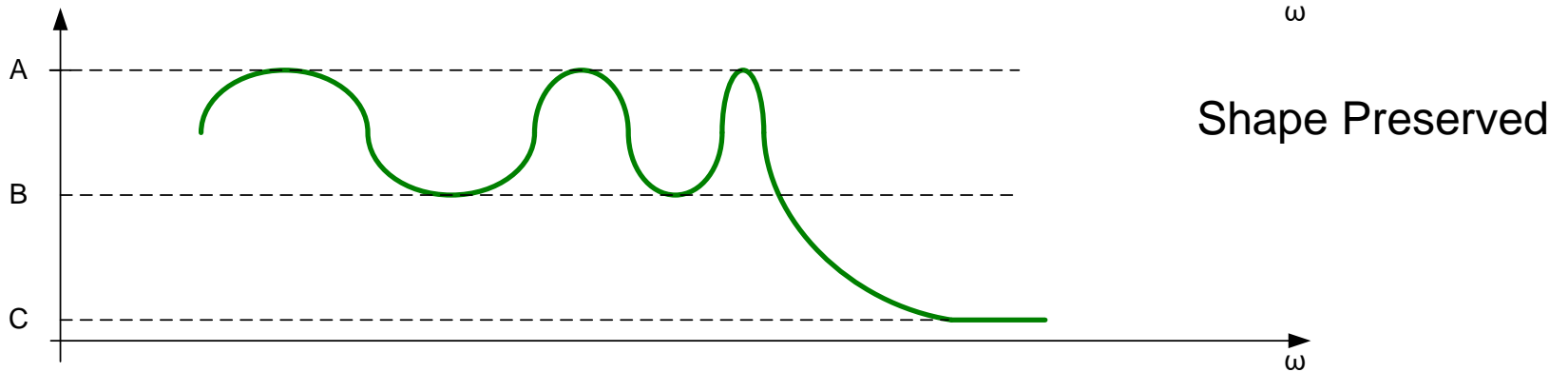
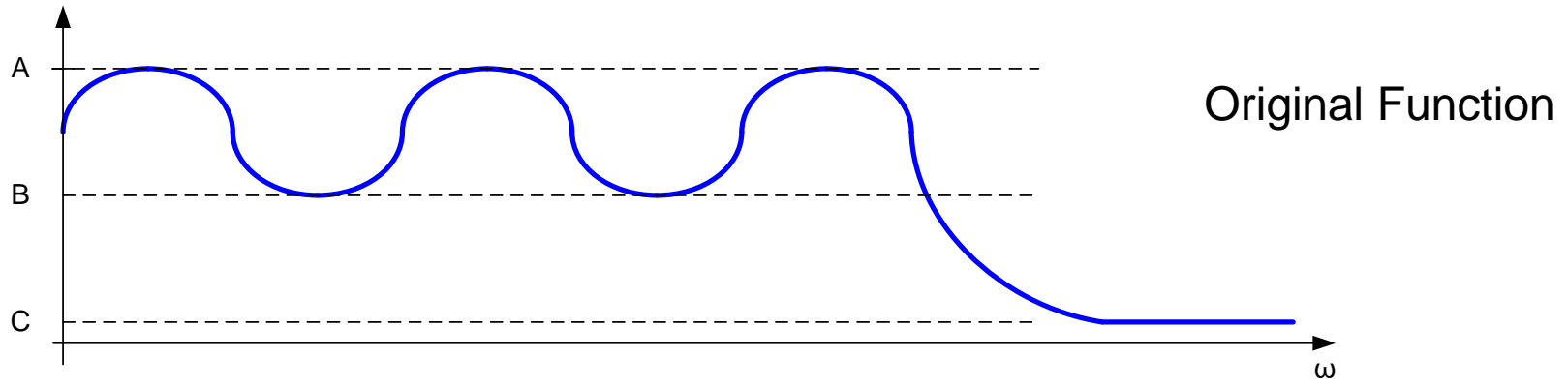

Example: Shape Preservation

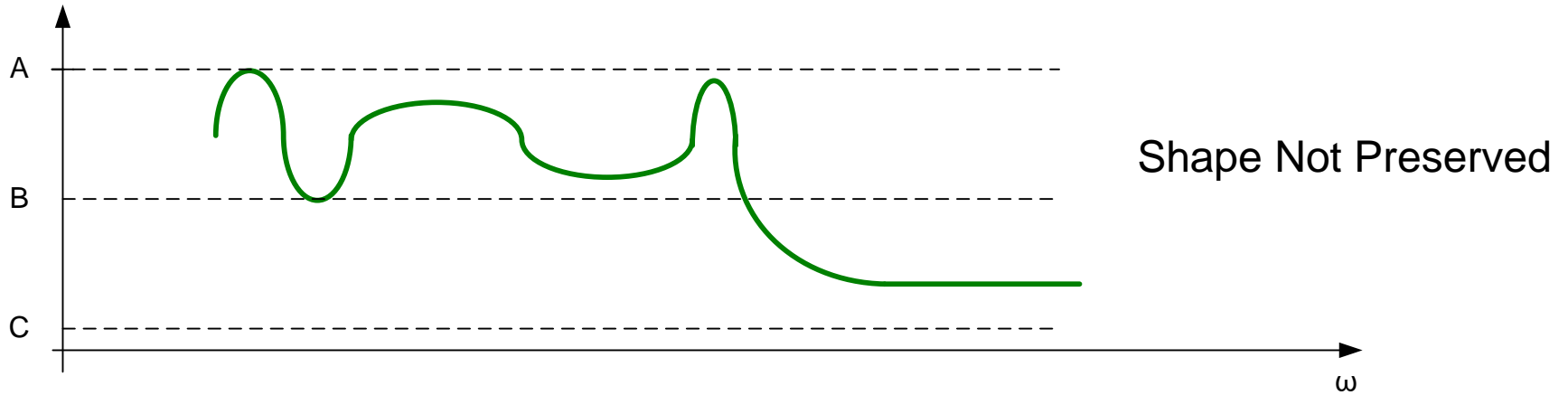
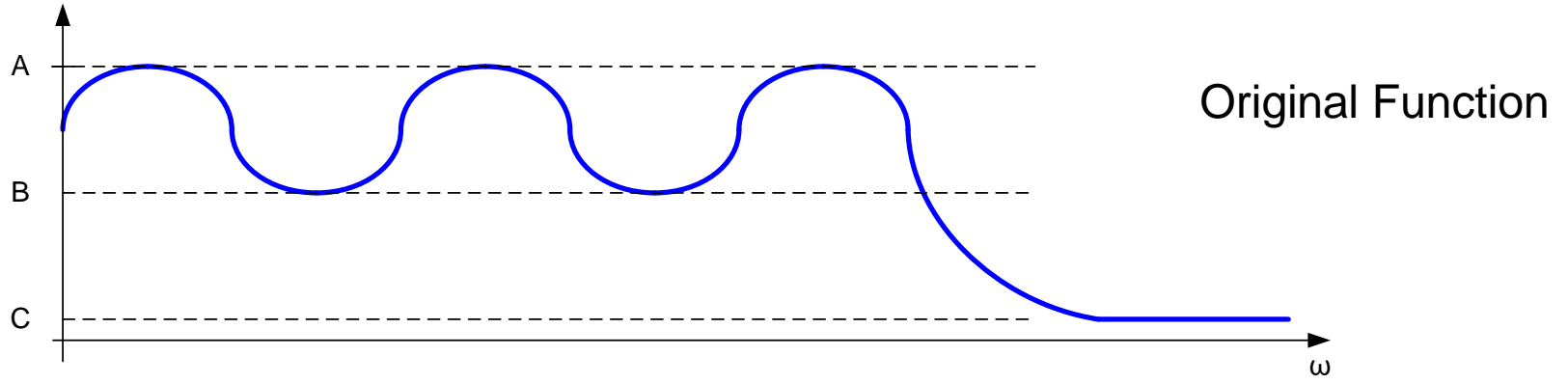

Flat Passband/Stopband Filters

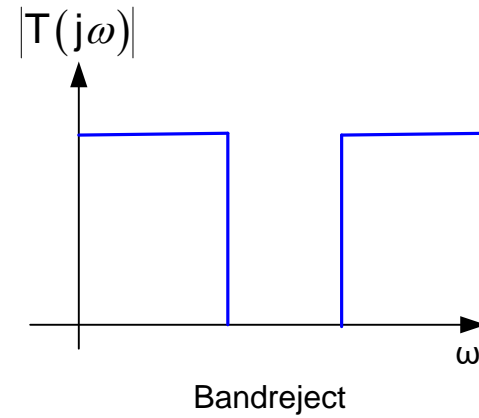
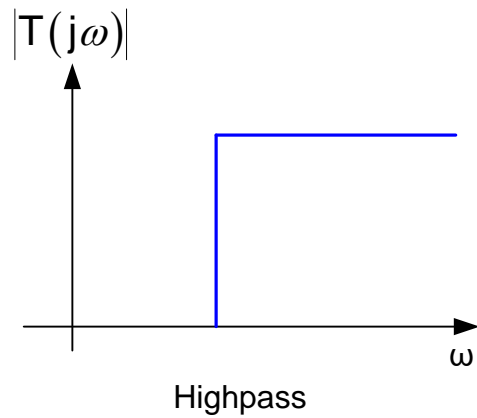
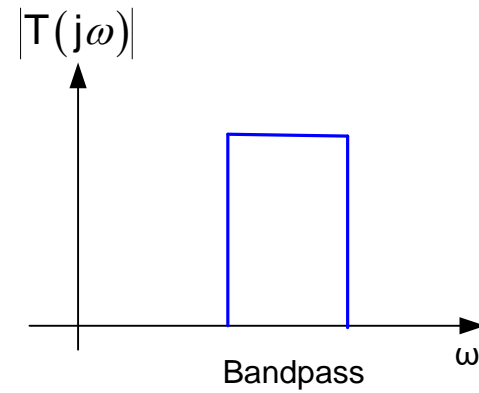
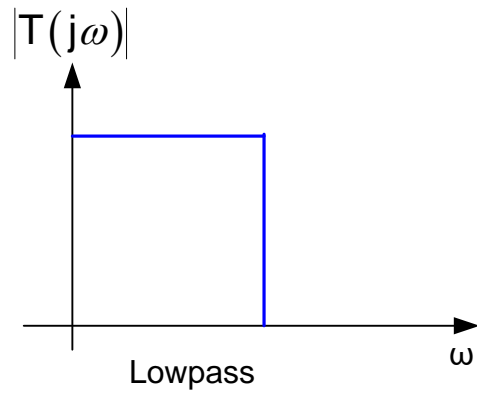

Filter Transformations



Lowpass to Bandpass (LP to BP)
Lowpass to Highpass (LP to HP)
Lowpass to Band-reject (LP to BR)

- Approach will be to take advantage of the results obtained for the standard LP approximations
- Will focus on flat passband and zero-gain stop-band transformations
- Will focus on transformations that map passband to passband, stopband to stopband, and Im axis to Im axis

LP to BP Filter Transformations

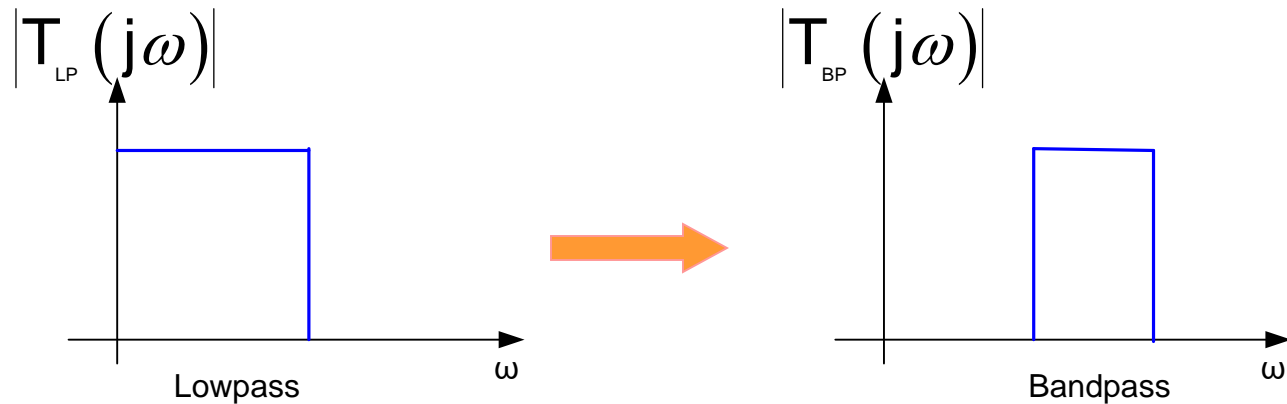
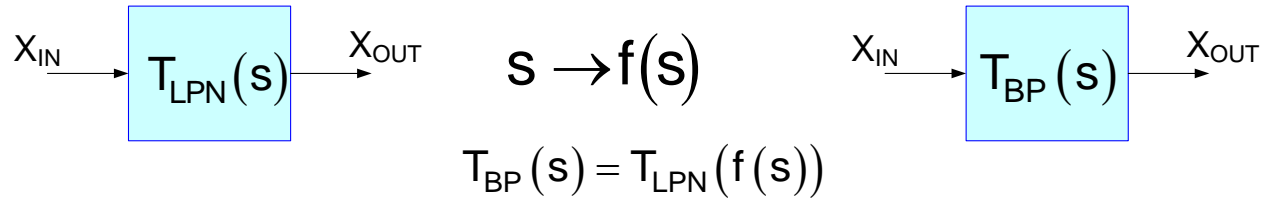

Will consider rational fraction mappings

$$f(s) = \frac{\sum_{i=0}^{m_T} a_{Ti} s^i}{\sum_{i=0}^{n_T} b_{Ti} s^i}$$

- Not all rational fraction mappings will map Im axis to the Im axis
- Not all rational fraction mappings will map passband to passband and stopband to stopband
- Consider only that subset of those mappings with these properties

LP to BP Transformation

Mapping Strategy: Consider first a mapping to a normalized BP approximation

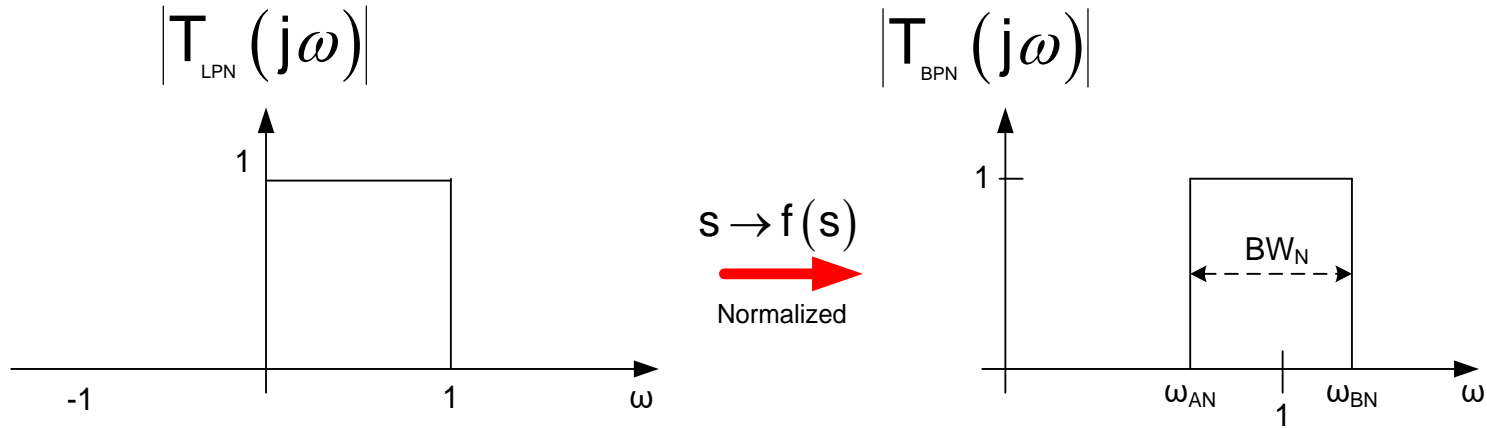

$$BW_N = \omega_{BN} - \omega_{AN}$$

$$\sqrt{\omega_{AN} \omega_{BN}} = 1$$

LP to BP Transformation

Mapping Strategy: Consider first a mapping to a normalized BP approximation

A mapping from $s \rightarrow f(s)$ will map the entire imaginary axis

Thus, must consider both positive and negative frequencies. Since $|T(j\omega)|$ is a function of ω^2 , the magnitude response on the negative ω axis will be a mirror image of that on the positive ω axis

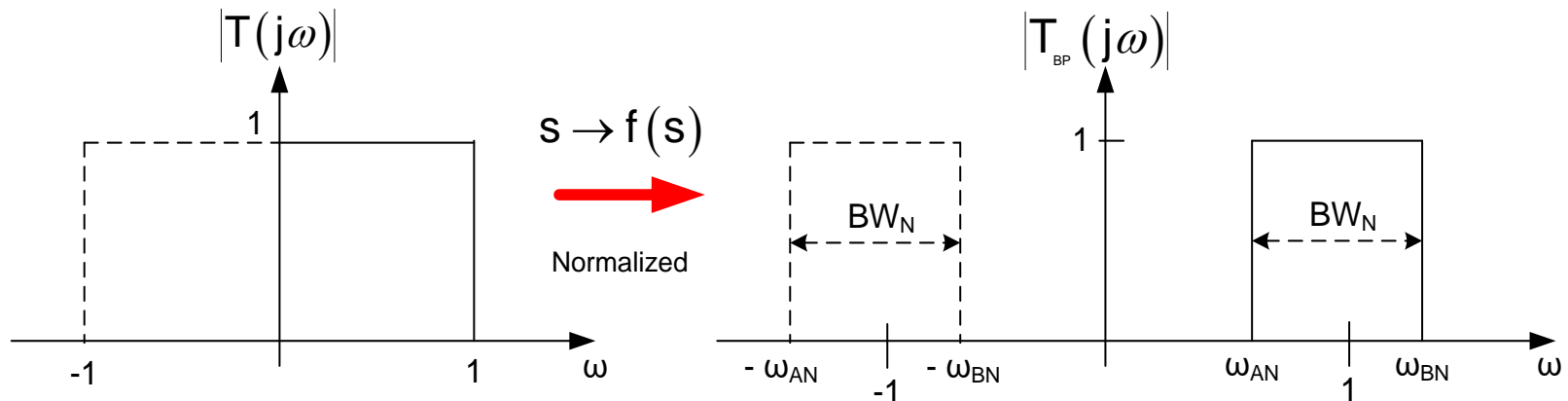

$$BW_N = \omega_{BN} - \omega_{AN}$$

$$\sqrt{\omega_{AN} \omega_{BN}} = 1$$

Standard LP to BP Transformation

Normalized LP to Normalized BP mapping Strategy:

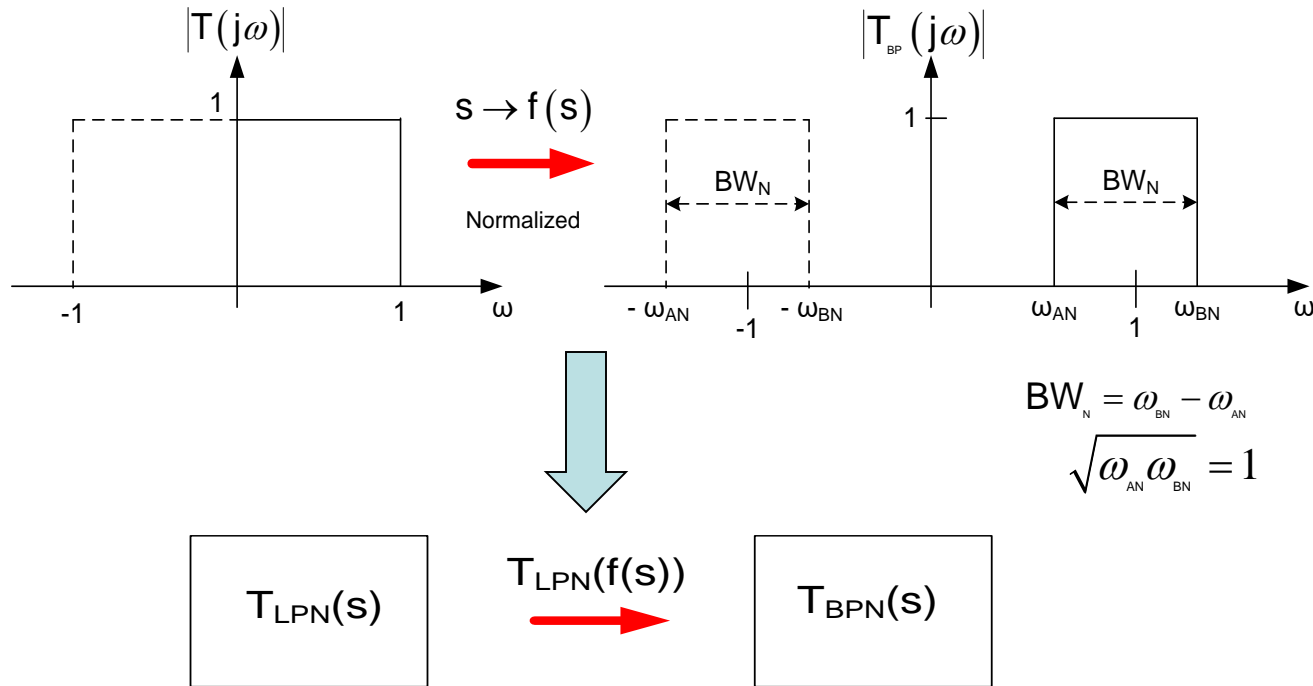

Variable Mapping Strategy to Preserve Shape of LP function:

consider:

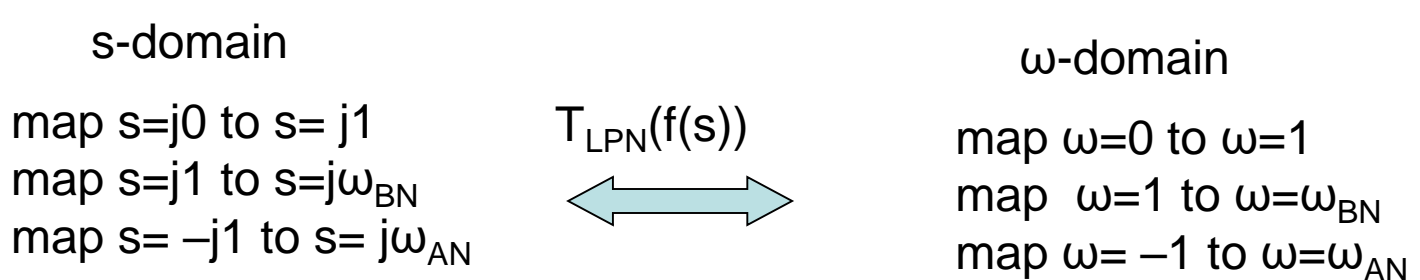

This mapping will introduce 3 constraints

Standard LP to BP Transformation

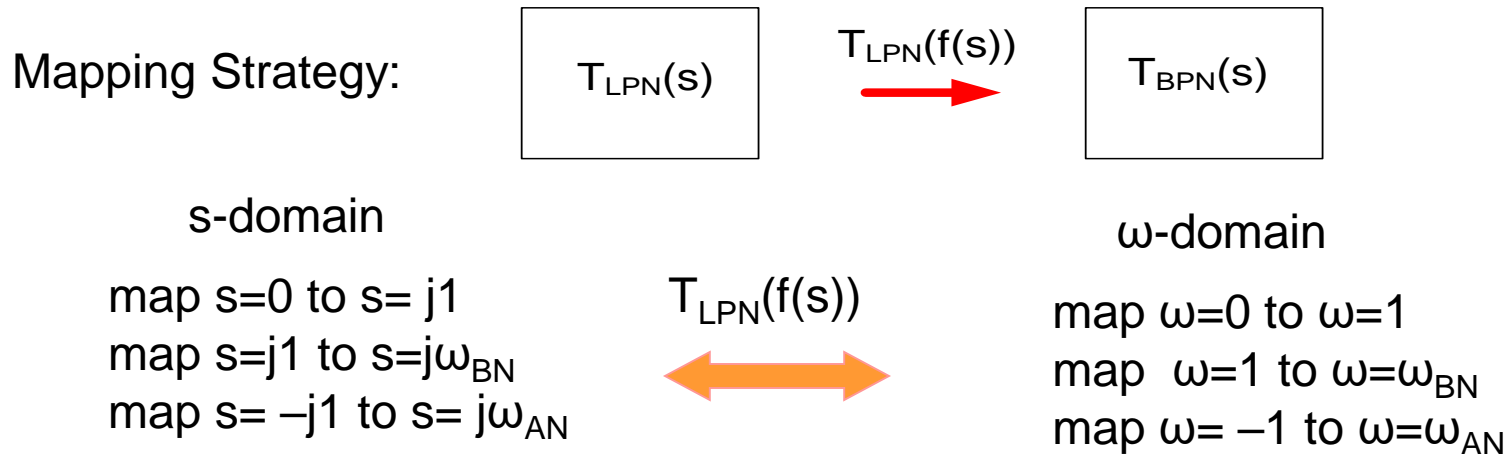

Consider variable mapping

$$f(s) = \frac{a_{T2}s^2 + a_{T1}s + a_{T0}}{b_{T1}s + b_{T0}}$$

With this mapping, there are 5 D.O.F and 3 mathematical constraints and the additional constraints that the Im axis maps to the Im axis and maps PB to PB and SB to SB

Will now show that the following mapping will meet these constraints

$$f(s) = \frac{s^2 + 1}{s \cdot BW_N} \quad \text{or} \quad s \rightarrow \frac{s^2 + 1}{s \cdot BW_N}$$

equivalently

This is the lowest-order mapping that will meet these constraints and it doubles the order of the approximation

Standard LP to BP Transformation

s-domain

map $s=0$ to $s=j1$
 map $s=j1$ to $s=j\omega_{BN}$
 map $s=-j1$ to $s=j\omega_{AN}$

$$T_{LPN}(f(s))$$

ω -domain

map $\omega=0$ to $\omega=1$
 map $\omega=1$ to $\omega=\omega_{BN}$
 map $\omega=-1$ to $\omega=\omega_{AN}$

Verification of mapping Strategy:

$$s \rightarrow \frac{s^2 + 1}{s \cdot BW_N}$$

$$\left. \frac{s^2 + 1}{s \cdot BW_N} \right|_{j1} = 0 \quad \Rightarrow \quad 0 \rightarrow j1$$

$$\left. \frac{s^2 + 1}{s \cdot BW_N} \right|_{j\omega_{BN}} = \frac{1 - \omega_{BN}^2}{j\omega_{BN} (\omega_{BN} - \omega_{AN})} = j \frac{\omega_{BN}^2 - 1}{\omega_{BN}^2 - \omega_{AN} \omega_{BN}} = j \frac{\omega_{BN}^2 - 1}{\omega_{BN}^2 - 1} = j \quad \Rightarrow \quad j1 \rightarrow j\omega_{BN}$$

$$\left. \frac{s^2 + 1}{s \cdot BW_N} \right|_{j\omega_{AN}} = \frac{1 - \omega_{AN}^2}{j\omega_{AN} (\omega_{BN} - \omega_{AN})} = j \frac{\omega_{AN}^2 - 1}{\omega_{AN} \omega_{BN} - \omega_{AN}^2} = j \frac{\omega_{AN}^2 - 1}{1 - \omega_{AN}^2} = -j \quad \Rightarrow \quad -j1 \rightarrow j\omega_{AN}$$

Must still show that the Im axis maps to the Im axis and maps PB to PB and SB to SB

Standard LP to BP Transformation

s-domain

map $s=0$ to $s=j1$
 map $s=j1$ to $s=j\omega_{BN}$
 map $s=-j1$ to $s=j\omega_{AN}$

$T_{LPN}(f(s))$

ω -domain

map $\omega=0$ to $\omega=1$
 map $\omega=1$ to $\omega=\omega_{BN}$
 map $\omega=-1$ to $\omega=\omega_{AN}$

Verification of mapping Strategy:

$$s \rightarrow \frac{s^2 + 1}{s \cdot BW_N}$$

Image of Im axis:

$$j\omega = \frac{s^2 + 1}{s \cdot BW_N}$$

solving for s, obtain

$$s = \frac{j\omega \cdot BW_N \pm \sqrt{(BW_N \cdot j\omega)^2 - 4}}{2} = j \left(\frac{\omega \cdot BW_N \pm \sqrt{(BW_N \cdot \omega)^2 + 4}}{2} \right)$$

this has no real part so the imaginary axis maps to the imaginary axis

Can readily show this mapping maps PB to PB and SB to SB

The mapping $s \rightarrow \frac{s^2 + 1}{s \cdot BW_N}$ is termed the standard LP to BP transformation

Standard LP to BP Transformation

The standard LP to BP transformation $s \rightarrow \frac{s^2 + 1}{s \cdot BW_N}$

If we add a subscript to the LP variable for notational convenience, can express this mapping as

$$s_x = \frac{s^2 + 1}{s \cdot BW_N}$$

Question: Is this mapping dimensionally consistent ?

- The dimensions of the constant “1” in the numerator must be set so that this is dimensionally consistent
- The dimensions of BW_N must be set so that this is dimensionally consistent

Standard LP to BP Transformation

$$T_{LPN}(s)$$

$$\begin{array}{c} s \\ \downarrow \\ \frac{s^2+1}{s \cdot BW_N} \end{array}$$

$$T_{BPN}(s)$$

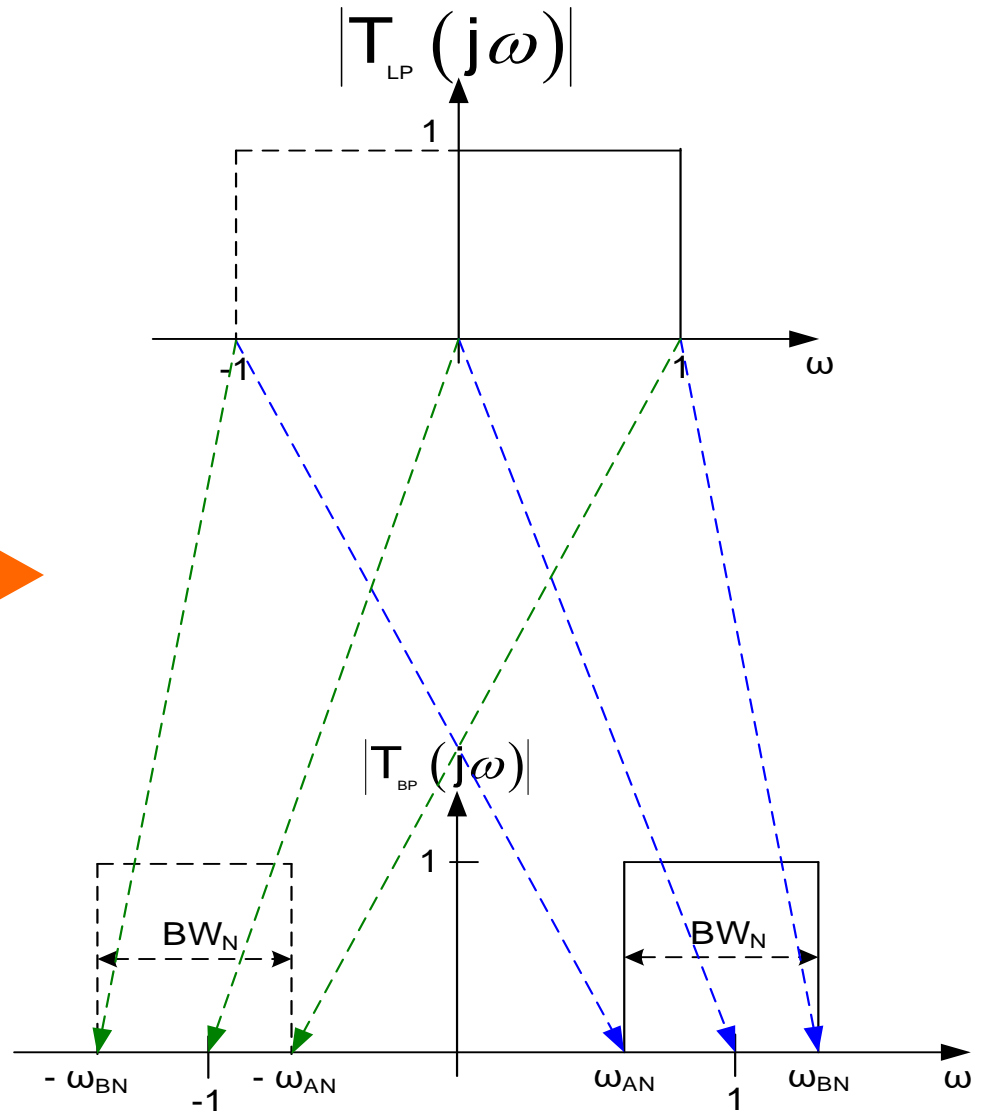

Standard LP to BP Transformation

Frequency and s-domain Mappings

(subscript variable in LP approximation for notational convenience)

$$T_{\text{LPN}}(s_x)$$

$$\begin{array}{c} s_x \\ \downarrow \\ \frac{s^2+1}{s \cdot BW_N} \end{array}$$

$$T_{\text{BPN}}(s)$$

$$s_x \rightarrow \frac{s^2+1}{s \cdot BW_N}$$

$$\omega_x \rightarrow \frac{\omega^2-1}{\omega \cdot BW_N}$$

solving for s or ω

$$s \leftarrow \frac{s_x \cdot BW_N \pm \sqrt{(BW_N \cdot s_x)^2 - 4}}{2}$$

$$\omega \leftarrow \frac{\omega_x \cdot BW_N \pm \sqrt{(BW_N \cdot \omega_x)^2 + 4}}{2}$$

Exercise: Resolve the dimensional consistency in the last equation

Standard LP to BP Transformation

Denormalized Mapping

$$T_{LPN}(s)$$

s



$$\frac{s^2 + \omega_M^2}{s \cdot BW}$$

$$T_{BP}(s)$$

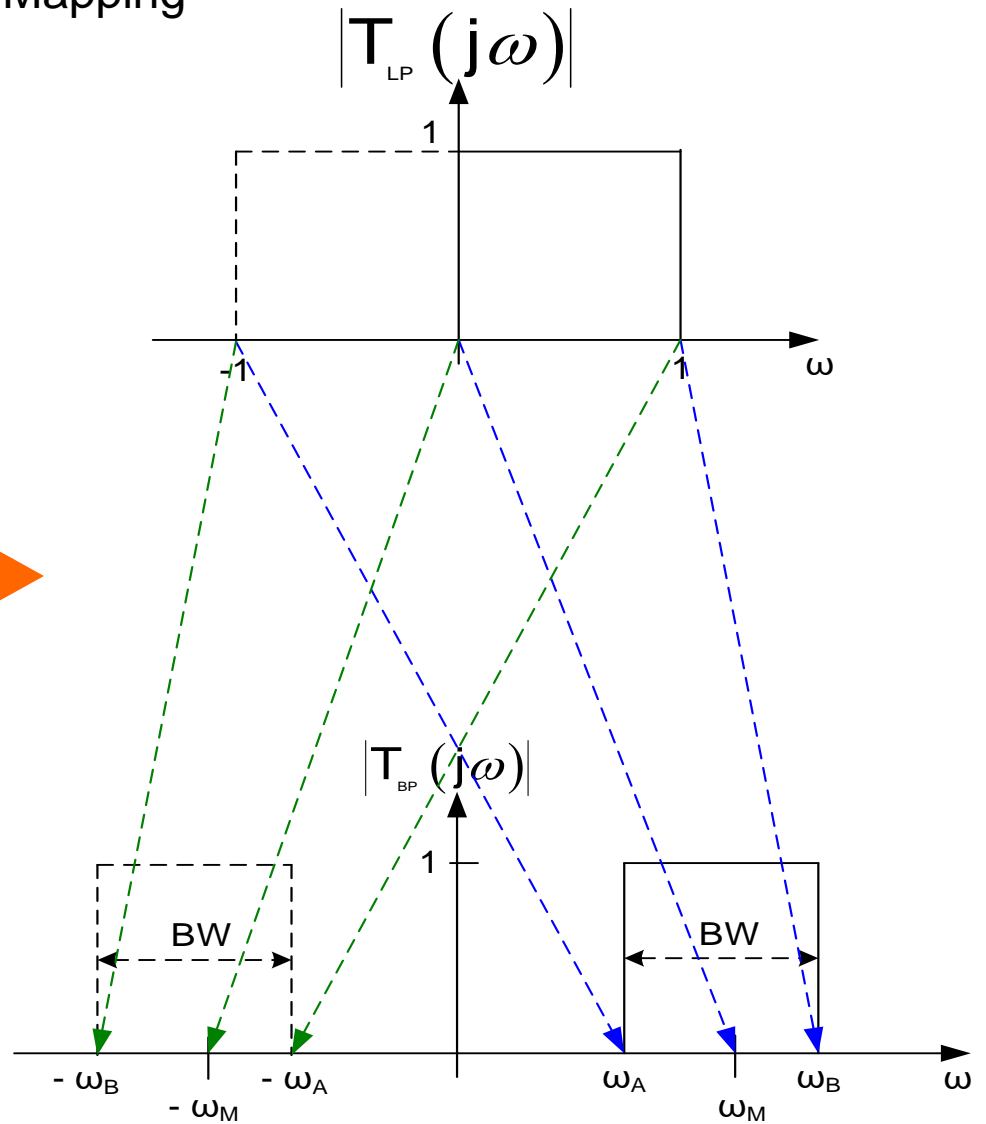

Standard LP to BP Transformation

Frequency and s-domain Mappings - Denormalized

(subscript variable in LP approximation for notational convenience)

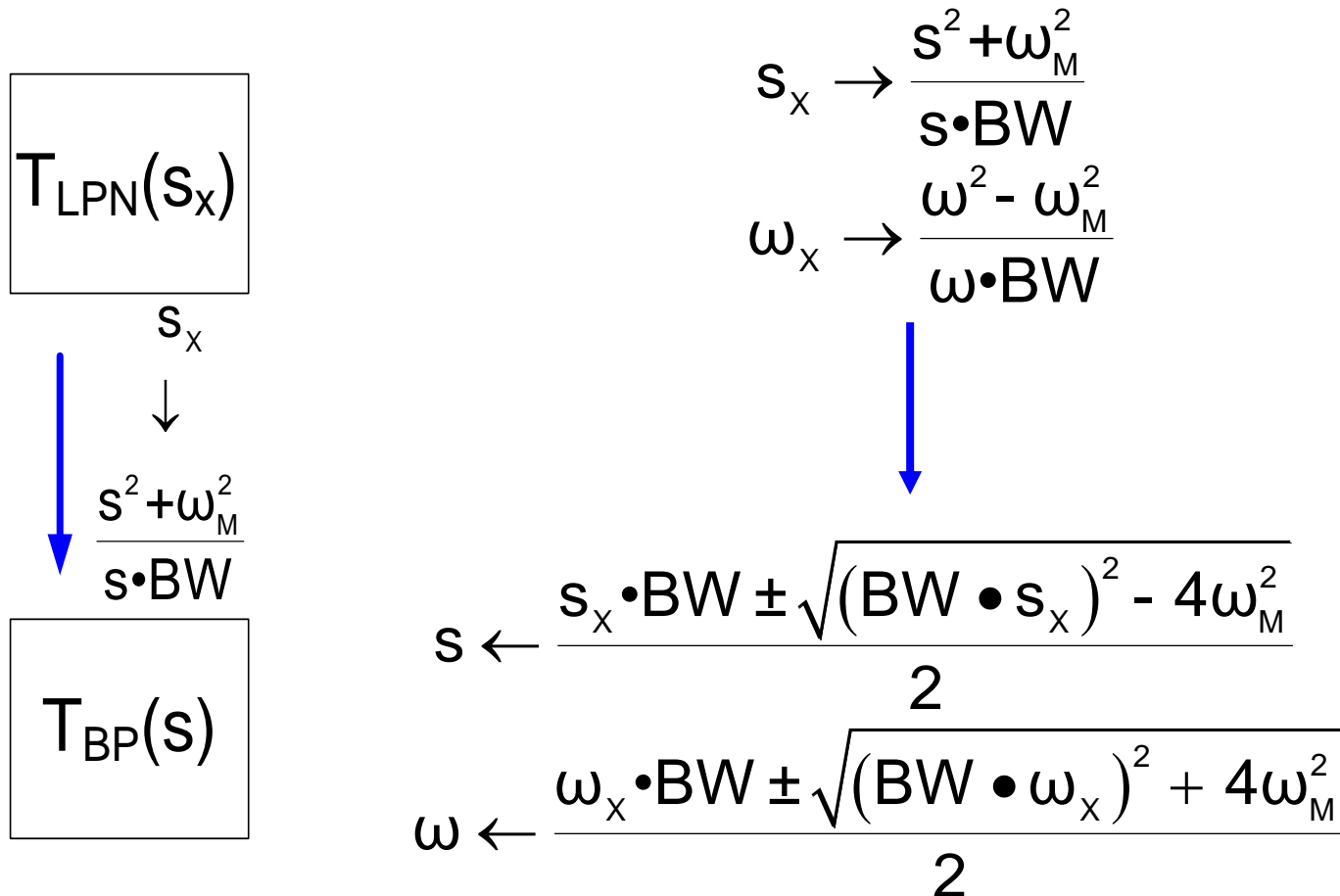

Exercise: Resolve the dimensional consistency in the last equation

Standard LP to BP Transformation

Frequency and s-domain Mappings - Denormalized

(subscript variable in LP approximation for notational convenience)

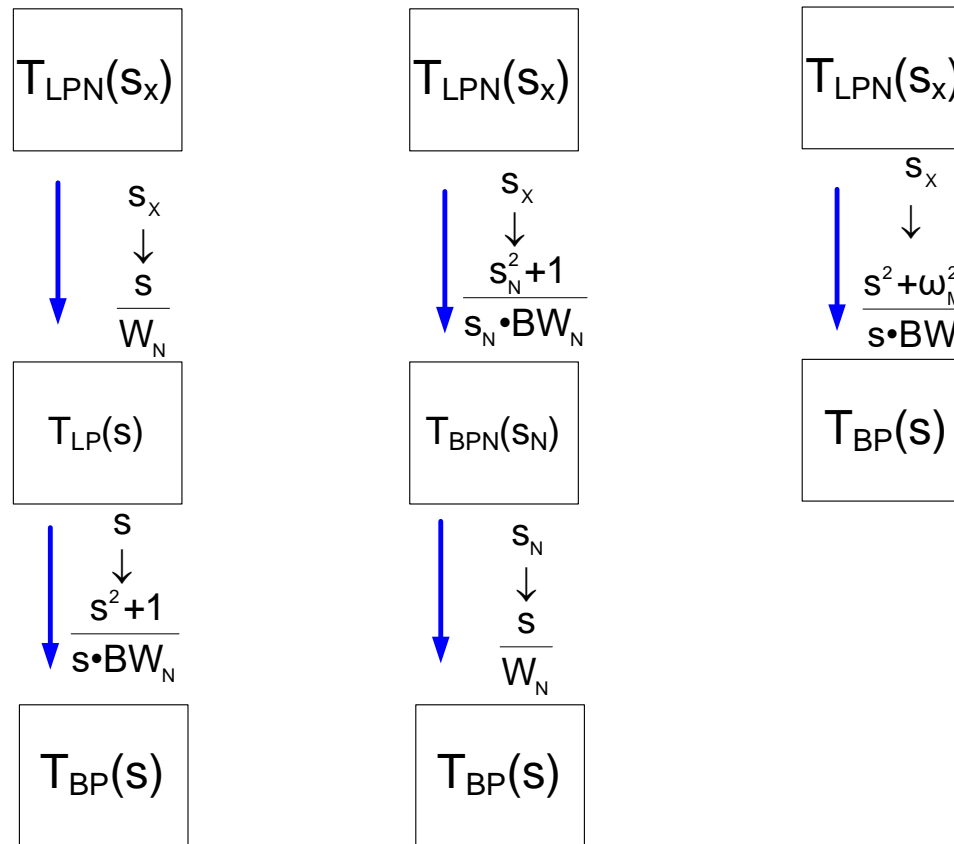

All three approaches give same approximation

Which is most practical to use?

Often none of them !

Standard LP to BP Transformation

Frequency and s-domain Mappings - Denormalized

(subscript variable in LP approximation for notational convenience)

$$T_{LPN}(s_x)$$

$$\begin{array}{c} s_x \\ \downarrow \\ \frac{s_N^2 + 1}{s_N \cdot BW_N} \end{array}$$

$$T_{BPN}(s_N)$$

Often most practical to synthesize directly from the T_{BPN} and then do the frequency scaling of components at the circuit level rather than at the approximation level

Standard LP to BP Transformation

Frequency and s-domain Mappings

(subscript variable in LP approximation for notational convenience)

Poles and Zeros of the BP approximations

$$s_x \xrightarrow{f} \frac{s^2 + 1}{s \cdot BW_N} \xrightarrow{\text{solving for } s} s \xleftarrow{f^{-1}} \frac{s_x \cdot BW_N \pm \sqrt{(BW_N \cdot s_x)^2 - 4}}{2}$$

$$T_{BP}(s) = T_{LPN}(f(s))$$

$$T_{LPN}(p_x) = 0$$

$$T_{LPN}(f(p)) = 0$$

$$T_{BP}(p) = T_{LPN}(f(p)) = 0$$

Since this relationship maps the complex plane to the complex plane, it also maps the poles and zeros of the LP approximation to the poles and zeros of the BP approximation

Standard LP to BP Transformation

Pole Mappings

Claim: With a variable mapping transform, the variable mapping naturally defines the mapping of the poles of the transformed function

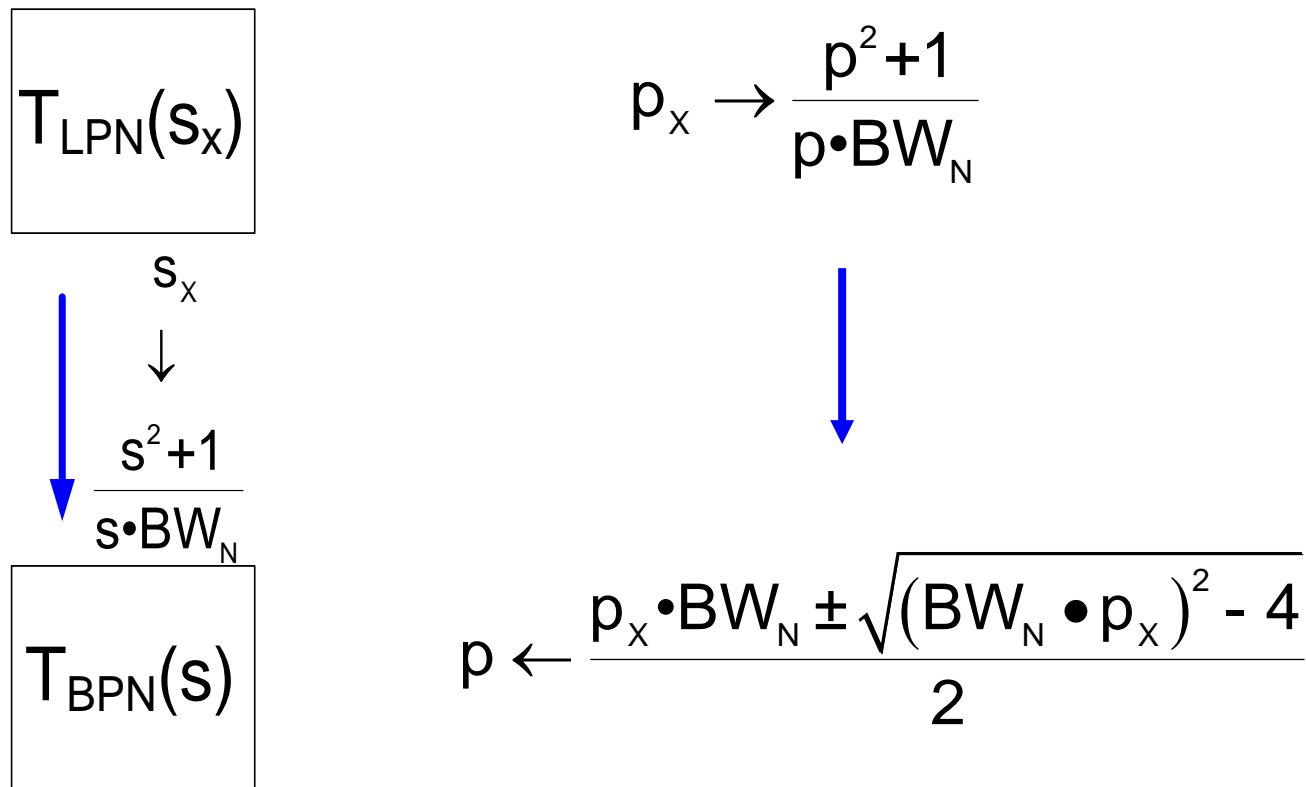

Exercise: Resolve the dimensional consistency in the last equation

Standard LP to BP Transformation

Pole Mappings

$$p \leftarrow \frac{p_x \cdot BW_N \pm \sqrt{(BW_N \cdot p_x)^2 - 4}}{2}$$

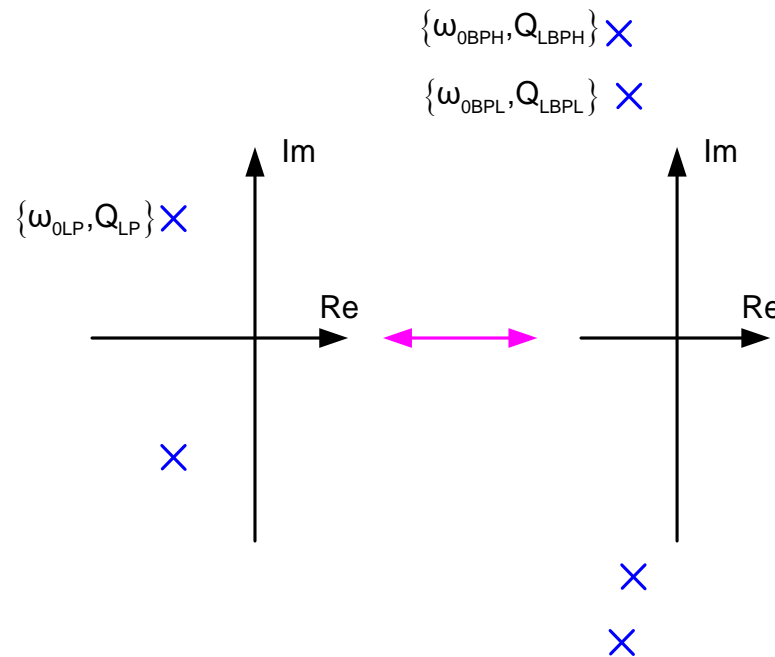
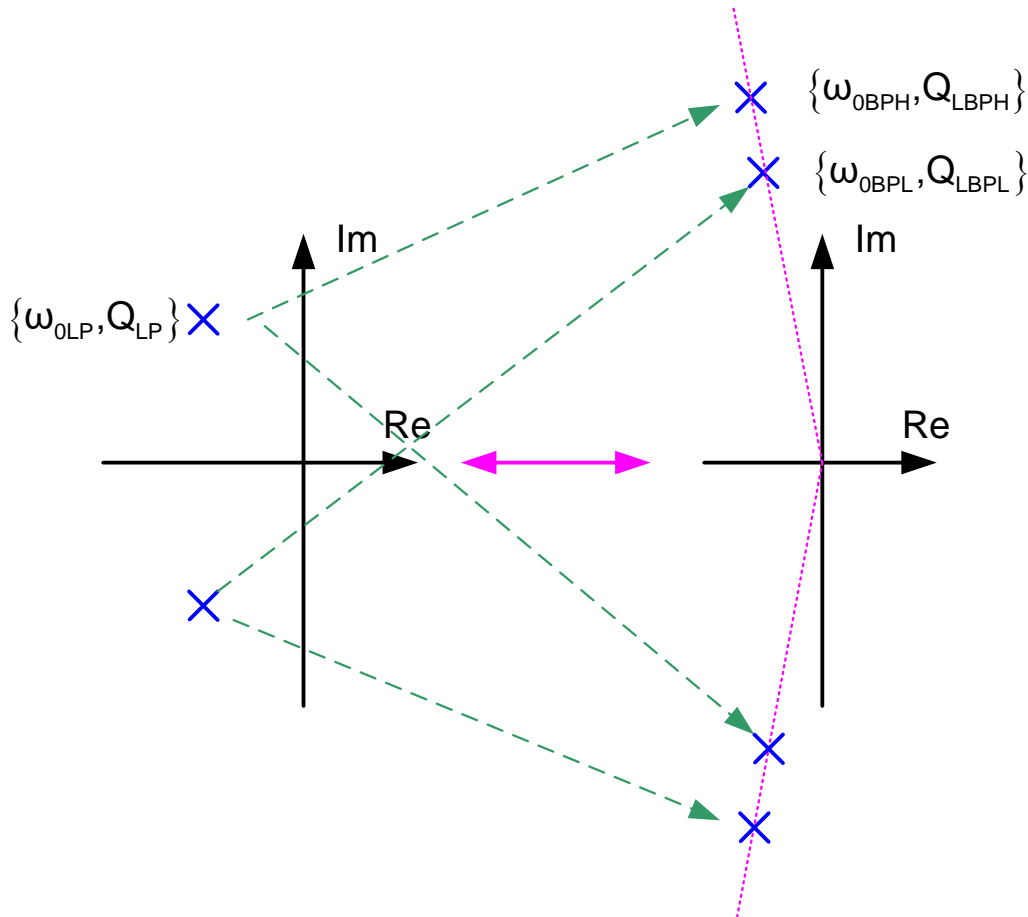

Image of the cc pole pair is the two pairs of poles

Standard LP to BP Transformation

Pole Mappings



Can show that the upper hp pole maps to one upper hp pole and one lower hp pole as shown. Corresponding mapping of the lower hp pole is also shown

Standard LP to BP Transformation

Pole Mappings

$$p \leftarrow \frac{p_x \cdot BW_N \pm \sqrt{(BW_N \cdot p_x)^2 - 4}}{2}$$

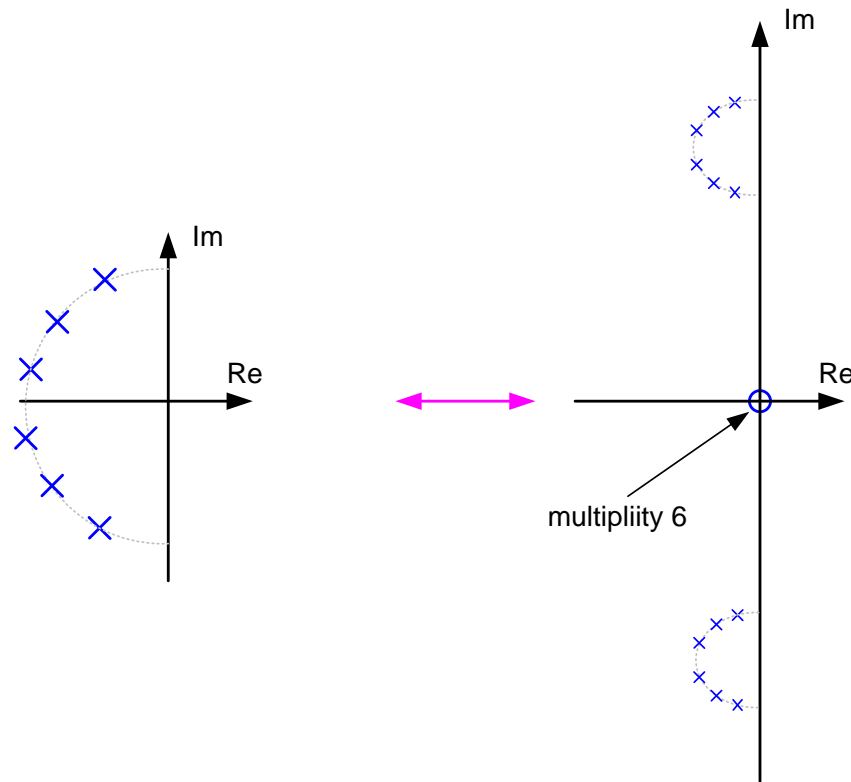

Note doubling of poles, addition of zeros, and likely Q enhancement

LP to BP Transformation

Claim: Other variable mapping transforms exist that satisfy the imaginary axis mapping properties needed to obtain the LP to BP transformation but are seldom, if ever, discussed. The Standard LP to BP transform is by far the most popular and most authors treat it as if it is unique.

$$T_{LPN}(s_x)$$

$$\begin{array}{c} \downarrow \\ s_x \\ \downarrow \\ f_2(s) \end{array}$$

$$T_{BPN}(s)$$

LP to BP Transformation

Pole Q of BP Approximations

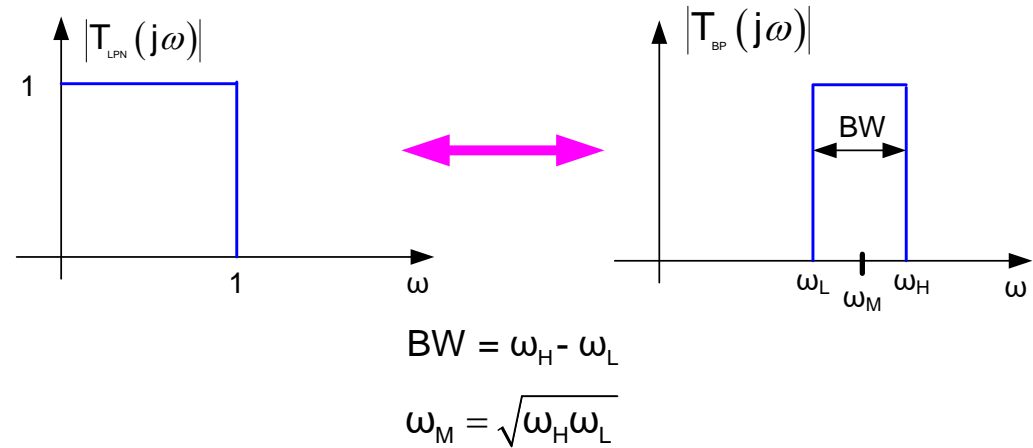

Consider a pole in the LP approximation characterized by $\{\omega_{0LP}, Q_{LP}\}$

It can be shown that the corresponding BP poles have the same Q
 (i.e. both bp poles lie on a common radial line)

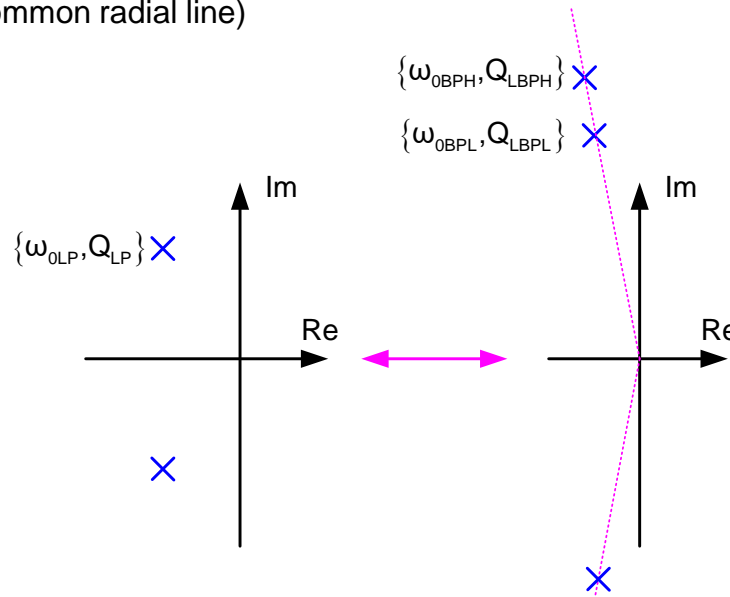

LP to BP Transformation

Pole Q of BP Approximations
(applies to any LP approximation)

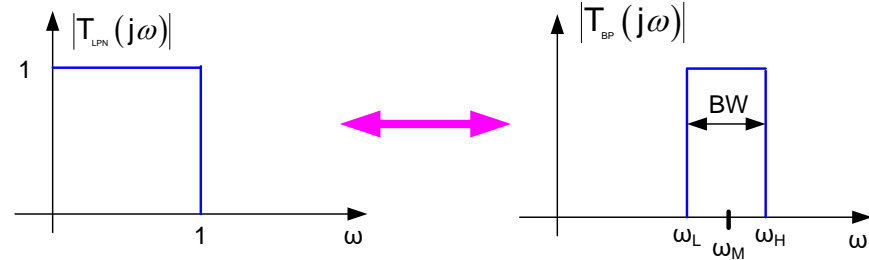
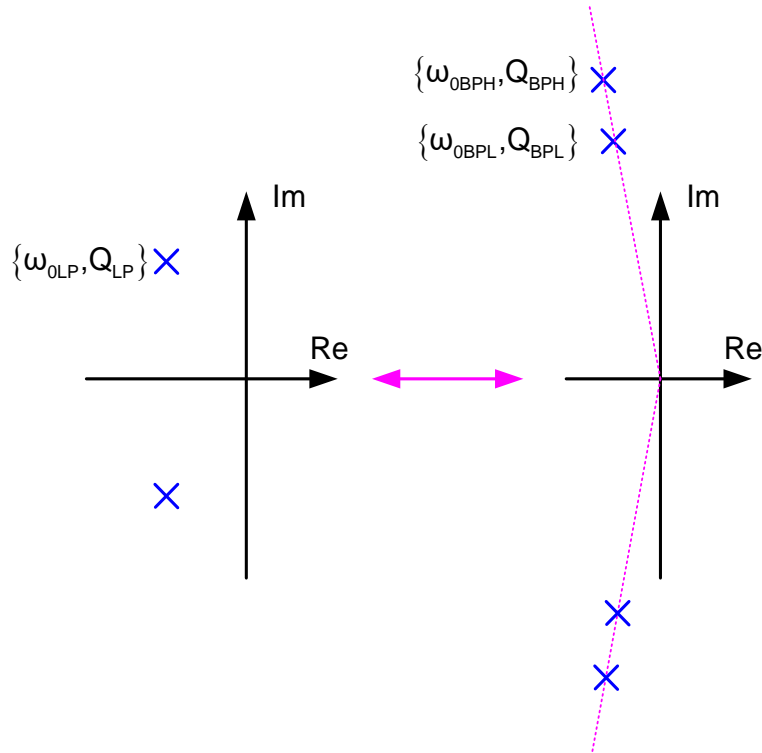

$$BW = \omega_H - \omega_L$$

$$\omega_M = \sqrt{\omega_H \omega_L}$$

Define:
$$\delta = \left(\frac{BW}{\omega_M} \right) \omega_{OLP}$$

It can be shown that

$$Q_{BPL} = Q_{BPH} = \frac{Q_{LP}}{\sqrt{2}} \sqrt{1 + \frac{4}{\delta^2} + \sqrt{\left(1 + \frac{4}{\delta^2}\right)^2 - \frac{4}{\delta^2 Q_{LP}^2}}}$$

For δ small,
$$Q_{BP} \cong \frac{2Q_{LP}}{\delta}$$

It can be shown that

$$\omega_{0BP} = \frac{\omega_M}{2} \left[\delta \frac{Q_{BP}}{Q_{LP}} \pm \sqrt{\left(\delta \frac{Q_{BP}}{Q_{LP}} \right)^2 - 4} \right]$$

Note for δ small, Q_{BP} can get very large

LP to BP Transformation

Pole Q of BP Approximations

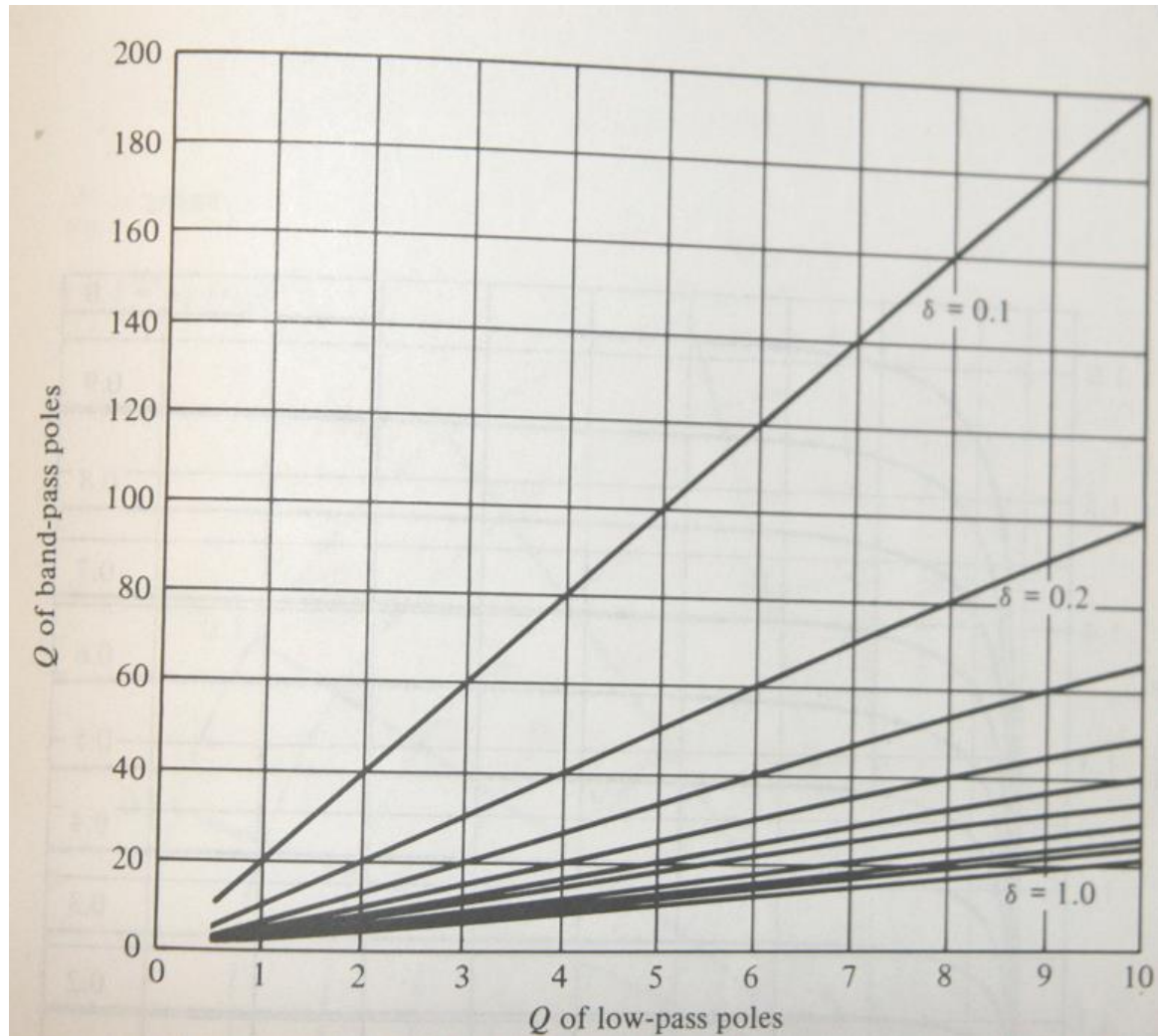

$$\delta = \left(\frac{BW}{\omega_M} \right) \omega_{OLP}$$

$$Q_{BPL} = Q_{BPH} = \frac{Q_{LP}}{\sqrt{2}} \sqrt{1 + \frac{4}{\delta^2} + \sqrt{\left(1 + \frac{4}{\delta^2}\right)^2 - \frac{4}{\delta^2 Q_{2LP}^2}}}$$

LP to BP Transformation

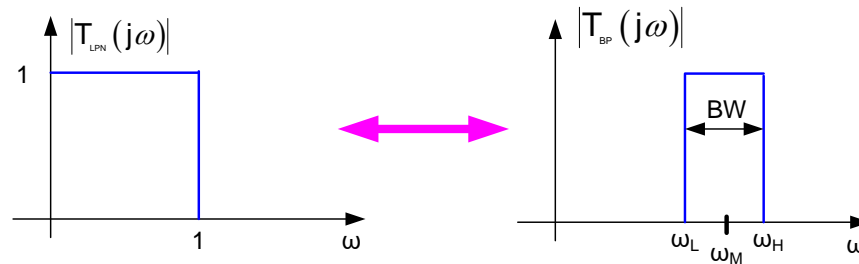

Classical BP Approximations

Butterworth
Chebyshev
Elliptic
Bessel

Obtained by the LP to BP transformation of the corresponding LP approximations

Standard LP to BP Transformation

$$s \rightarrow \frac{s^2 + 1}{s \cdot BW_N}$$

- Standard LP to BP transform is a variable mapping transform
- Maps $j\omega$ axis to $j\omega$ axis
- Maps LP poles to BP poles
- Preserves basic shape but warps frequency axis
- Doubles order
- Pole Q of resultant band-pass functions can be very large for narrow pass-band
- Sequencing of frequency scaling and transformation does not affect final function

Example 1: Obtain an approximation that meets the following specifications

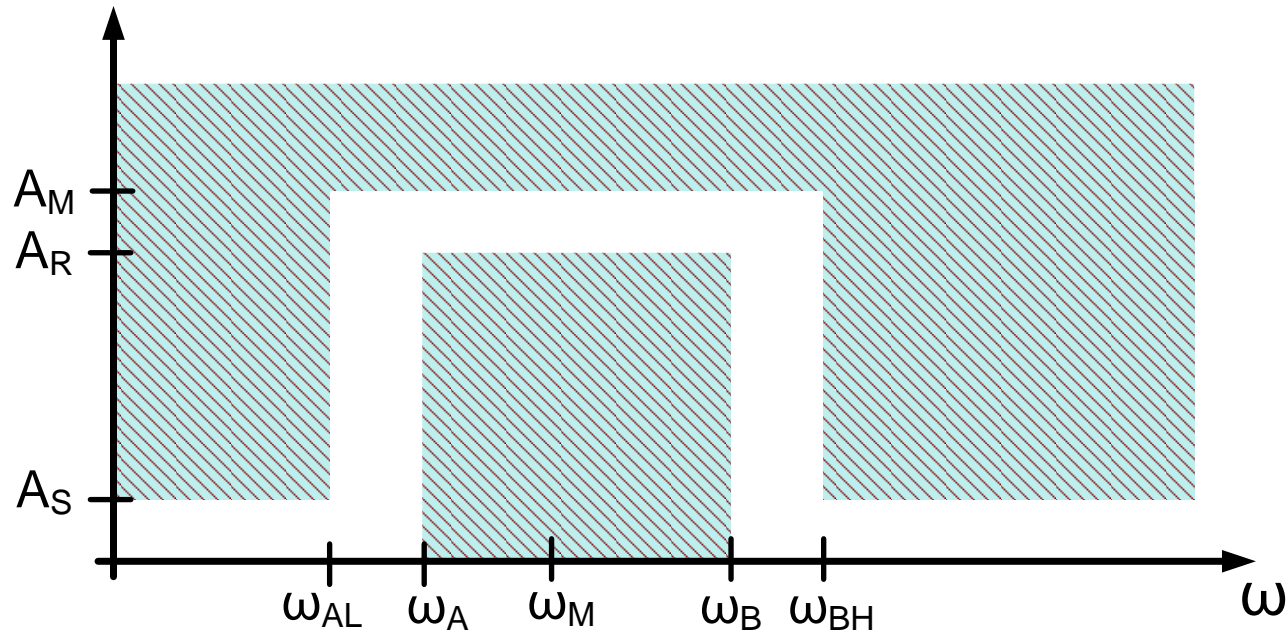

$$BW = \omega_B - \omega_A$$

$$\omega_M = \sqrt{\omega_B \cdot \omega_A}$$

Assume that ω_{AL} , ω_{BH} and ω_M satisfy

$$\frac{\omega_M^2 - \omega_{AL}^2}{\omega_{AL} \cdot BW} = \frac{\omega_{BH}^2 - \omega_M^2}{\omega_{BH} \cdot BW}$$

Recall from above:

Standard LP to BP Transformation

Frequency and s-domain Mappings - Denormalized

(subscript variable in LP approximation for notational convenience)

$$T_{LPN}(s_x)$$

s_x

↓

$$\frac{s^2 + \omega_M^2}{s \cdot BW}$$

$$T_{BP}(s)$$

$$s_x \rightarrow \frac{s^2 + \omega_M^2}{s \cdot BW}$$

$$\omega_x \rightarrow \frac{\omega^2 - \omega_M^2}{\omega \cdot BW}$$

$$s \leftarrow \frac{s_x \cdot BW \pm \sqrt{(BW \cdot s_x)^2 - 4\omega_M^2}}{2}$$

$$\omega \leftarrow \frac{\omega_x \cdot BW \pm \sqrt{(BW \cdot \omega_x)^2 + 4\omega_M^2}}{2}$$

Example 1: Obtain an approximation that meets the following specifications

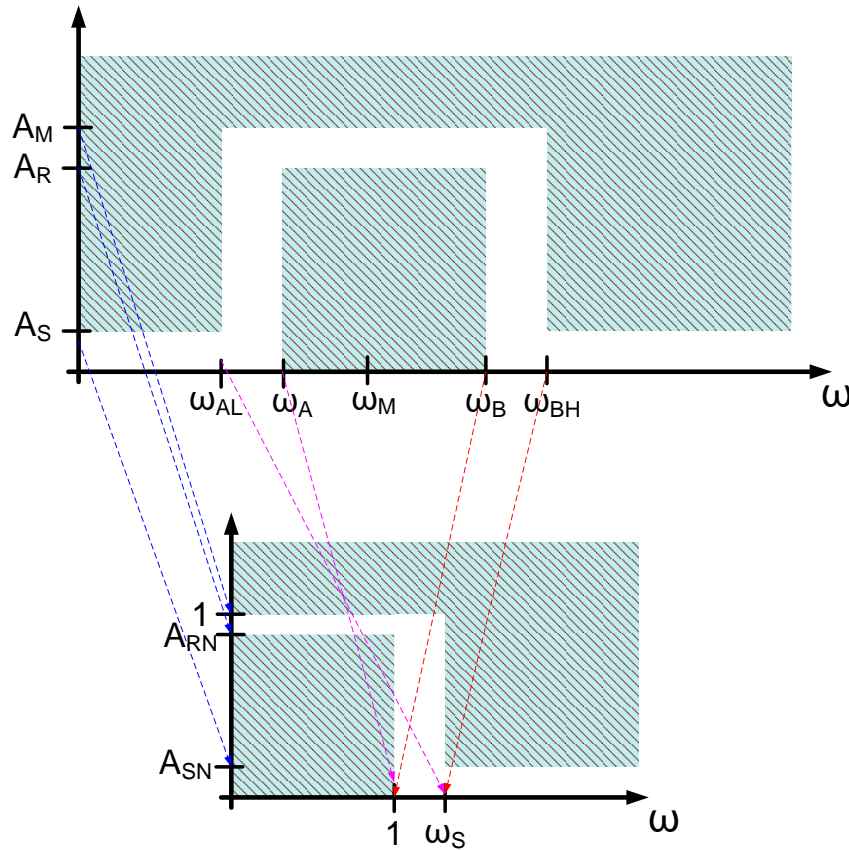

$$A_{RN} = \frac{A_R}{A_M}$$

$$A_{SN} = \frac{A_S}{A_M}$$

$$\frac{1}{\sqrt{1+\epsilon^2}} = \frac{A_R}{A_M}$$

$$\epsilon = \sqrt{\left(\frac{A_M}{A_R}\right)^2 - 1}$$

$$\omega_s = \frac{\omega_M^2 - \omega_{AL}^2}{\omega_{AL} \cdot BW}$$

$$BW = \omega_B - \omega_A$$

$$\omega_M = \sqrt{\omega_B \cdot \omega_A}$$

$$\frac{\omega_M^2 - \omega_{AL}^2}{\omega_{AL} \cdot BW} = \frac{\omega_{BH}^2 - \omega_M^2}{\omega_{BH} \cdot BW}$$

(actually ω_A and ω_{AL} that map to -1 and $-\omega_s$ respectively but show 1 and ω_s for convenience)

Example 2: Obtain an approximation that meets the following specifications

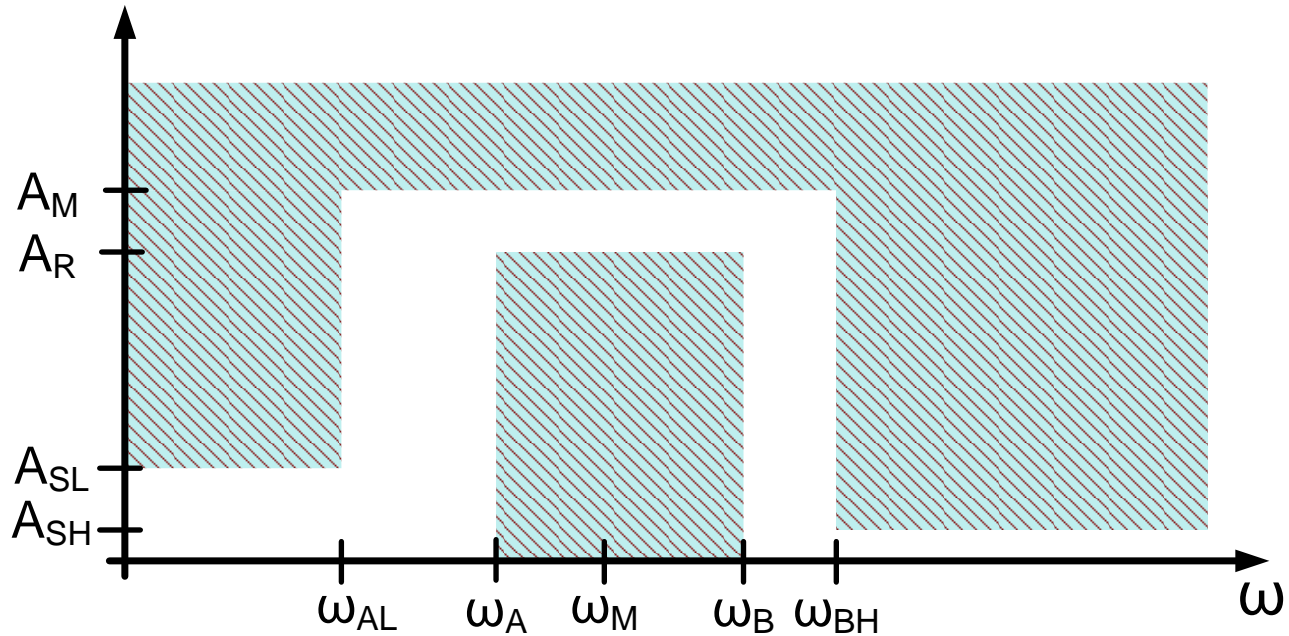

$$BW = \omega_B - \omega_A$$

$$\omega_M = \sqrt{\omega_B \cdot \omega_A}$$

In this example,

$$\frac{\omega_M^2 - \omega_{AL}^2}{\omega_{AL} \cdot BW} \neq \frac{\omega_{BH}^2 - \omega_M^2}{\omega_{BH} \cdot BW}$$

Example 2: Obtain an approximation that meets the following specifications

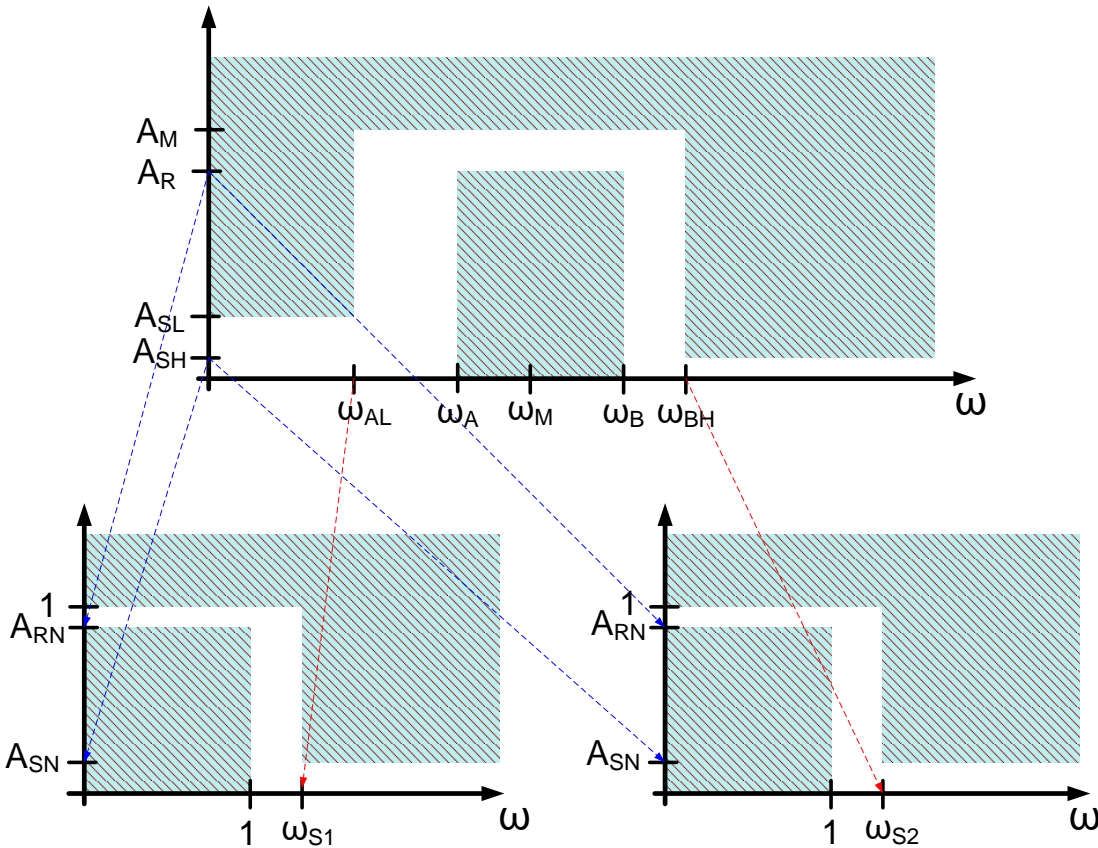

$$BW = \omega_B - \omega_A$$

$$\omega_M = \sqrt{\omega_B \cdot \omega_A}$$

$$A_{RN} = \frac{A_R}{A_M}$$

$$\frac{1}{\sqrt{1+\epsilon^2}} = \frac{A_R}{A_M}$$

$$A_{SN} = \min \left\{ \frac{A_{SH}}{A_M}, \frac{A_{SL}}{A_M} \right\}$$

$$\epsilon = \sqrt{\left(\frac{A_M}{A_R} \right)^2 - 1}$$

$$\omega_{S1} = \frac{\omega_M^2 - \omega_{AL}^2}{\omega_{AL} \cdot BW}$$

$$\omega_{S2} = \frac{\omega_{BH}^2 - \omega_M^2}{\omega_{BH} \cdot BW}$$

$$\omega_{SN} = \min \{ \omega_{S1}, \omega_{S2} \}$$

Example 2: Obtain an approximation that meets the following specifications

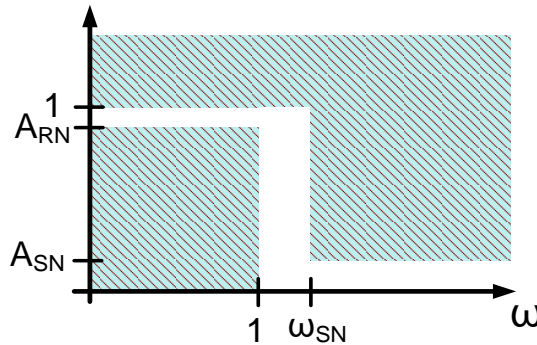
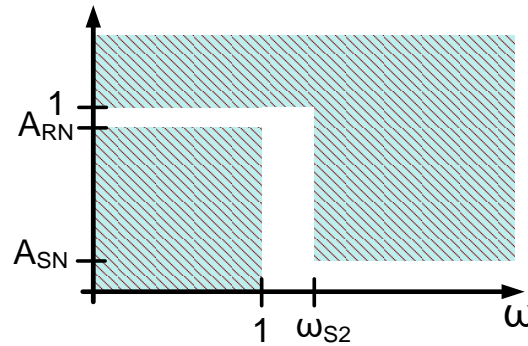
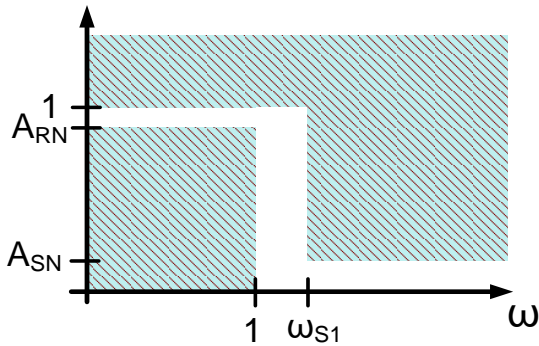

$$\omega_{SN} = \min\{\omega_{S1}, \omega_{S2}\}$$

$$A_{RN} = \frac{A_R}{A_M}$$

$$\frac{1}{\sqrt{1+\varepsilon^2}} = \frac{A_R}{A_M}$$

$$A_{SN} = \min\left\{\frac{A_{SH}}{A_M}, \frac{A_{SL}}{A_M}\right\}$$

$$\varepsilon = \sqrt{\left(\frac{A_M}{A_R}\right)^2 - 1}$$

$$\omega_{S1} = \frac{\omega_M^2 - \omega_{AL}^2}{\omega_{AL} \cdot BW}$$

$$\omega_{S2} = \frac{\omega_{BH}^2 - \omega_M^2}{\omega_{BH} \cdot BW}$$

$$BW = \omega_B - \omega_A$$

$$\omega_M = \sqrt{\omega_B \cdot \omega_A}$$

$$\omega_{SN} = \min\{\omega_{S1}, \omega_{S2}\}$$



Stay Safe and Stay Healthy !

End of Lecture 15